

Vertikale Ballenpresse
Vertical baling press



KOMPAKT

K 65

K 70

K 65/2

K 70/2

Geringer Platzbedarf *Minimum space*

Diese Universalballenpresse bringt große Leistung auf kleinstem Raum.

This universal applicable baling press offers great performance in the smallest possible space.



Vielseitig einsetzbar *Universal application*

Daher beliebt in Hotels, Restaurants, Shops, KFZ-Werkstätten, Handel und Gewerbe, etc.

Therefore often used in hotels, restaurants, shops, factories, offices, etc.

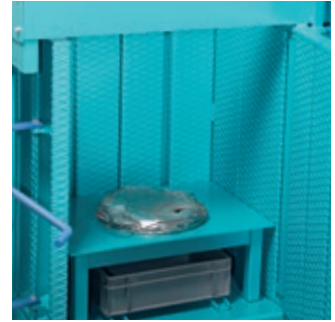

Einfaches Bindsystem *Simple bale strapping*

Der kompakte Ballen wird verknotet und einfach aus der Maschine genommen.

The compact bale is tied together and taken out of the machine easily.



KOMPAKT K 65 | K 70 | K 65/2 | K 70/2

Vertikale Ballenpresse *Vertical baling press*

1000 fach bewährt *1000 times approved*

Die Pressen der Serie KOMPAKT sind die kostengünstigsten Lösungen für alle Abfallprobleme und amortisieren sich innerhalb kürzester Zeit. Sie verdichten mühelos Kartonagen, Papier, Obstkisten, Folien, Dosen, PET-Flaschen oder Blechfässer bis 60 Liter auf ein Minimum.

The presses of the series KOMPAKT are the most reasonable solutions and pay for themselves in short time. They easily compact cardboard, paper, fruit baskets, plastic film, cans, PET bottles or tins and barrels up to 60 liters to a minimum.



Saubere Lösung *Clean solution*

Einsackvorrichtung für Restmüll oder Kleinteile bei Ein- und Mehrkammersystem K 65.

Bagging attachment for waste or small parts for single or multi-chamber system K 65.



Praktisches Mehrkammersystem *Practical multi-chamber system*

Sortieren und Verdichten in einem. Eine Erweiterung mit zusätzlichen Kammern ist jederzeit möglich.

Sorting and pressing all in one. It is possible to extend with extra chambers at any time.

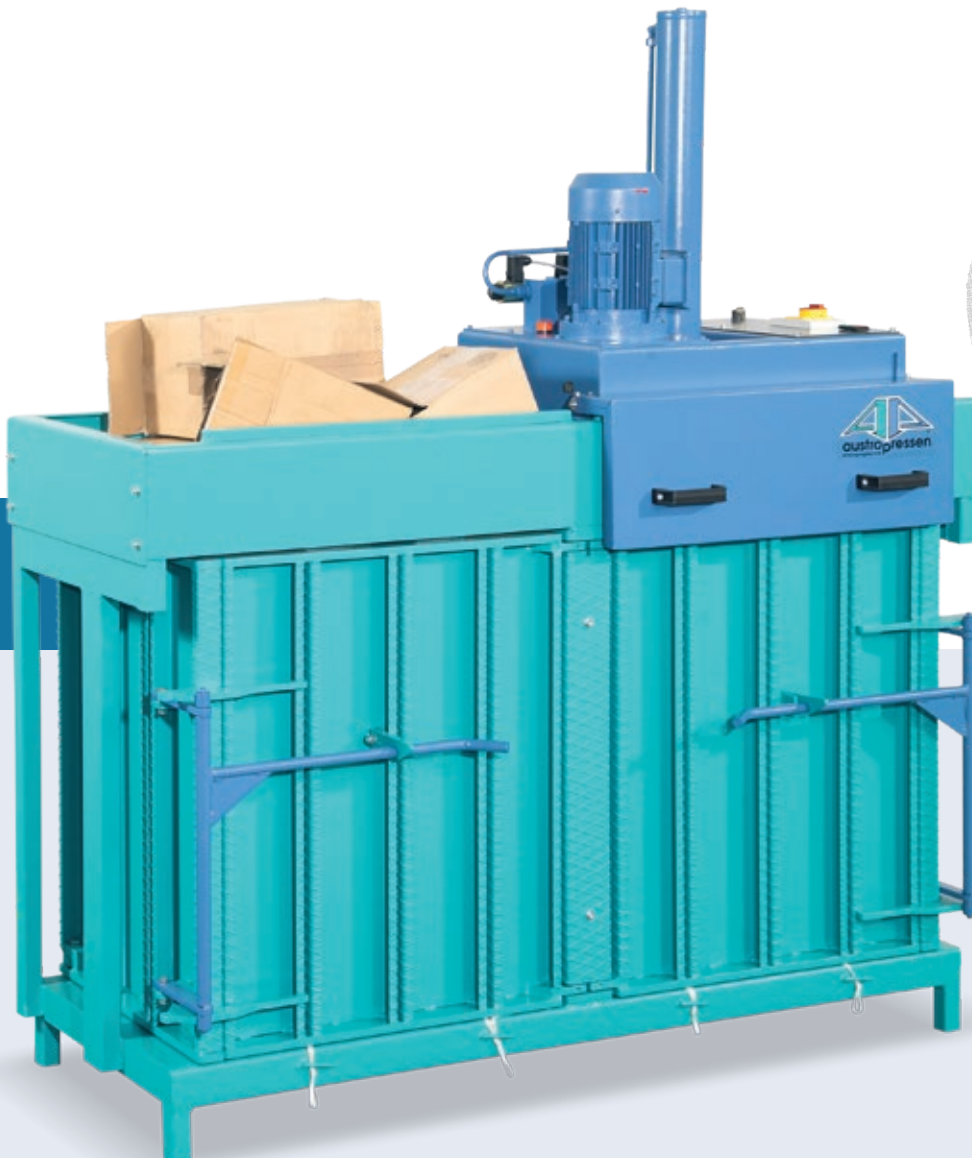

Technische Daten

Technical data

		K 65	K 70	K 65/2	K 70/2
Presskraft Pressing force	kN	50	60	50	60
Antrieb 400V * Motor 400V *	kW	1,5	1,5	1,5	1,5
Presszyklus Cycle time	sec	20	25	20	25
Presskammer bxtxh Box size wxdxh	mm	650x450x850	700x500x850	650x450x850	700x500x850
Füllöffnung Loading aperture	mm	650x450	700x500	650x450	700x500
Füllhöhe Loading height	mm	1020	1070	1280	1280
Ballenformat bxhxl Bale dimensions wxhxl	mm	650x450x450	700x500x500	650x450x450	700x500x500
Ballengewicht Bale weight	kg	30-60	40-80	30-60	40-80
Bindung Strapping		2v	2v	2v	2v
Abmaße bxtxh Overall dimensions wxdxh	mm	910x1090x1900	950x1180x1950	1710x850x1980	1810x900x2000
Gewicht Total weight	kg	345	400	550	620

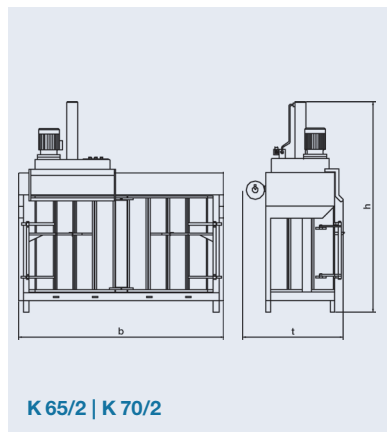
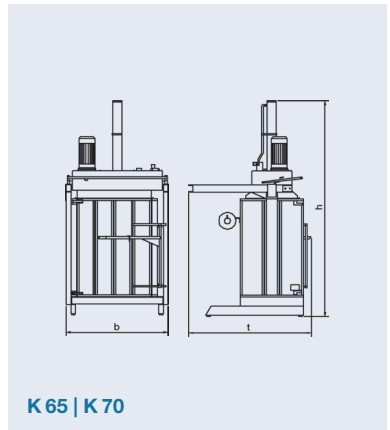

CE Conform/Conformity

* Option 230V

Technische Änderungen vorbehalten - Technical data subject to change

Produktpalette

Product range

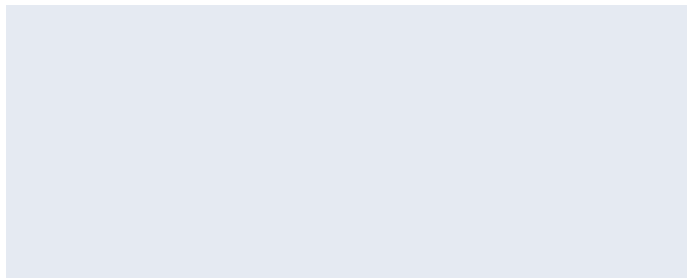

Druck- und Satzfehler sowie Irrtümer vorbehalten. Agentur L&M, www.lum.at



Roither Maschinenbau GmbH
 4863 Seewalchen, Austria
 Industriegebiet 11
 Tel.: +43 (0)7662/8218
 Fax: +43 (0)7662/8218 21
 sales@austropressen.com
 www.austropressen.com

