



THOMAS DÖRR
KITCHENSOLUTIONS

CUTLERY SORTING MACHINE

YOUR ADVANTAGES AT A GLANCE:

- **Full automatic, single-variety counting and sorting of cutlery**
- **Possible feeding solution via cutlery polishing machine**
Polishing and sorting in just one step
- **Possible connection to the conveyor dishwasher by means of conveying technology**
Fully automatic process of washing, polishing and sorting
- **Project-related and individual customized solutions possible**
- **Expandable amount of sorting bins**
- **Individual setting of the sorted amount for each bin**
- **Simple operation due to the intuitive touch panel display**
- **Time saving due to high degree of automation**
- **Flexible use due to mobility**

Made in Germany
www.t-td.com

EXPLANATION SORTING PROCESS

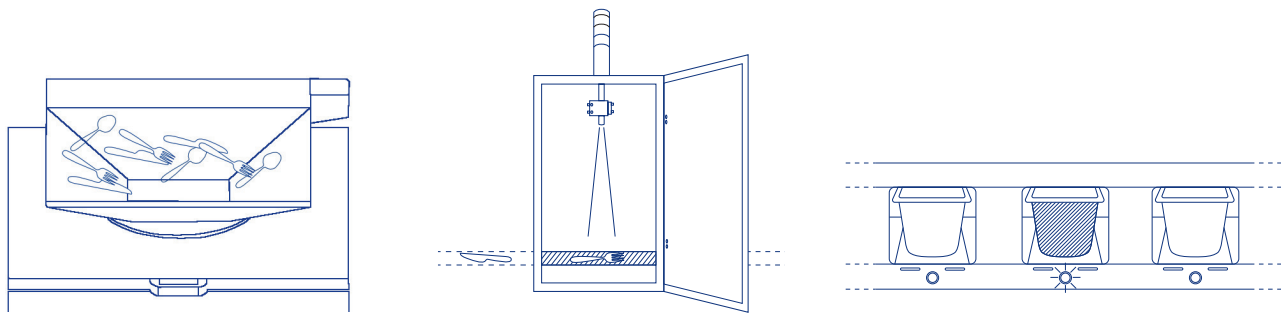

1

The unsorted cutlery pieces are either inserted manually or directly from the cutlery lane of the conveyor dishwasher

2

With the help of a specially developed camera system, the cutlery is identified according to size and shape and sorted into bins according to the direction of the handle.

3

Once the preset filling capacity has been reached it will be signaled by a lamp lighting up. Afterwards the bin is replaced manually.



VARIATIONS

Feeding solution via integrated cutlery polishing machine

The clean, wet cutlery is poured directly onto the feed chute in batch quantities from where it is automatically portioned into the cutlery polishing machine. The cutlery polishing machine automatically transfers the dried and polished cutlery on to the separating belts inside of the cutlery sorting machine.

The machine identifies, counts and sorts the different magnetic or non-magnetic cutlery pieces according to the direction of the handle into the bins.*

Feeding solution via conveyor system with possible connection to a dishwasher

The clean, dry cutlery is either fed directly from the cutlery lane of the dishwasher, or from a conveyor belt in which the cutlery has been poured onto manually. The feeding conveyor automatically transports the unsorted cutlery to the separation conveyors inside of the cutlery sorting machine. The machine identifies, counts and sorts the different magnetic or non-magnetic cutlery pieces according to the direction of the handle into the bins.*

FACTS AND FIGURES:

- Price: on request
- Sorting capacity: Approx. 3,000 cutlery items per hour
- Variation with cutlery polishing machine:
Dimensions: (W x H x D) 4.630 x 1.910 x 895 mm
Connected load: approx. 3,3 kW

- Variation with conveyor belt:
Dimensions and connected load will vary depending on the execution. Details upon request
- Stainless steel full panel covering
- Power supply: 230 V - 50/60 Hz

*limited with small cutlery items

